

SPATIO-TEMPORAL RESOLUTION OF DIFFERENT FLOW MEASUREMENT TECHNIQUES FOR MARINE RENEWABLE ENERGY APPLICATIONS

Vincent Lyon¹ and Martin Wosnik
Center for Ocean Renewable Energy (CORE)
University of New Hampshire
Durham, NH

¹Corresponding author: vslyon@gmail.com

ABSTRACT

Marine hydrokinetic (MHK) energy conversion devices are subject to a wide range of turbulent scales, either due to upstream bathymetry, obstacles and waves, or from wakes of upstream devices in array configurations. The commonly used, robust Acoustic Doppler Current Profilers (ADCP) are well suited for long term flow measurements in the marine environment, but are limited to low sampling rates due to their operational principle. The resulting temporal and spatial resolution is insufficient to measure all turbulence scales of interest to the device, e.g., "blade-scale turbulence." The present study systematically characterizes the spatial and temporal resolution of ADCP and Acoustic Doppler Velocimetry (ADV). Simulations were used to quantitatively investigate the flow scales that each of the instruments can resolve in low and high turbulence intensity flows. For comparison, measurements were conducted at the UNH Tidal Energy Test Site in Great Bay Estuary at General Sullivan Bridge. The purpose of the study is to supply data for mathematical modeling to improve predictions from ADCP measurements, which can help lead to higher-fidelity energy resource assessment and more accurate device evaluation, including wake measurements.

INTRODUCTION

Accurate flow measurement techniques are required for MHK design and implementation. Wake recovery is governed, and enhanced, by free stream turbulence, implying that an accurate measure of the energy contained at different turbulent scales is desirable. Similarly, accurate wake measurements are necessary for improved estimates of power extraction and efficient array spacing. Improving the accuracy of field and

laboratory flow measurements also improves confidence in the model validation process.

Additionally, field measurement techniques must be robust in order to produce repeatable results in the rough marine environment. These requirements generally introduce a tradeoff between measurement resolution and accuracy, field of view, and convenience of use. In particular, this paper will consider an Acoustic Doppler Current Profiler (ADCP) and an Acoustic Doppler Velocimeter (ADV), with comparison to higher resolution optical and thermal laboratory techniques for flow measurement.

An ADCP operates by transmitting a broadband acoustic signal into the water column and processing the phase shift of the reflected signal it receives from scatterers following the flow. Using three or more acoustic transducers, an ADCP can measure three components of velocity by performing a coordinate transformation from along-beam velocities to the vertical and cardinal directions [1]. The underlying assumption in the coordinate transformation is that the velocities in a horizontal plane at a given depth in each diverging beam are the same. This assumption is necessary because the tangential velocity components are lost by the acoustic measurement technique. Only the radial components can be obtained. By temporally gating the received signal, an ADCP can measure a velocity profile in discrete bins along the water column. Due to their diverging, conical beams, the measurement volume of these devices grows with depth. Bin sizes on the order of 25 cm in the vertical direction over a depth of 8 m, would result in a range of cylindrical measurement volumes from ~73-13,600 cm³ at a temporal resolution on the order of 1 Hz.

TABLE 1: COMPARATIVE OVERVIEW OF FLOW MEASUREMENT TECHNIQUES

	ADCP	ADV	PIV	LDV	Hot Film/Wire
<i>Operating Principle</i>	Acoustic	Acoustic	Optical	Optical	Thermal
<i>Spatial Resolution</i>	O(10-10 ⁴ cm ³)	O(1 cm ³)	O(1 mm ³)	O(10 ⁻³ mm ³)	O(10 ⁻³ - 1 mm ³)
<i>Temporal Resolution</i>	O(1 Hz)	O(100 Hz)	O(1 kHz)	O(1 kHz)	O(1 - 10 kHz)
<i>Measurement Description</i>	3D Profile, along beam	3D, point	2D or 3D, in plane	2D or 3D, point	1D (2D or 3D possible), point
<i>Comparative Cost</i>	\$	\$	\$\$\$	\$\$\$	\$\$
<i>Application</i>	Field	Field/Lab	Lab	Lab	Lab

An ADV follows a similar operating principle but for a singular measurement volume and at a much higher sampling rate. An ADV analyzes the Doppler shift of the scattered signal to determine the flow velocity [2]. These devices typically have a measurement volume on the order of 1 cm³ and temporal resolution on the order of 100 Hz.

This can be compared to higher resolution laboratory flow measurement techniques, e.g., optical techniques such as Particle Image Velocimetry (PIV) and Laser Doppler Velocimetry (LDV). PIV uses high-powered pulsed lasers and light-sheet forming optics to illuminate seeding particles in a measurement plane. Images are recorded onto a CCD or CMOS sensor with a controlled time interval, Δt . The field of view is divided into small interrogation regions and a correlation algorithm yields the peak-correlated particle displacement, and hence the fluid velocity. Fine control of optical alignment, focus, aperture, and timing are critical to the precision and accuracy of this flow measurement technique, making this technique better suited for lab use. Although numerous factors affect the resolution of a PIV system, spatial resolution is on the order of 1 mm³ for typical sensors and fields of view, and temporal resolution is on the order of 1 kHz for high frame rate systems [3].

Laser Doppler Velocimetry (LDV) is also an optical flow measurement technique, but its operating principle is more closely related to an ADV. For LDV, beams of coherent laser light are crossed in a small measurement volume and form an interference fringe pattern. When seeding particles pass through the fringes, they scatter light at a frequency which is equivalent to the Doppler shift between the incident and scattered light and thus proportional to the component of particle velocity [4]. Typically LDV offers spatial resolution on the order of 10⁻³ mm³ and variable temporal resolution, with sufficient seeding O(1 kHz) data rates are possible.

Hot film/wire anemometry operates on thermal principles: a probe with a conductive (hot) film at the tip is heated to a temperature higher than the average temperature of the fluid. As the probe resistance changes due to convective heat transfer from the film, a feedback circuit applies a voltage to keep the film at a constant temperature. The fluid velocity is related nonlinearly to the voltage applied, and can be found via calibration. Higher order 2-D and 3-D turbulence measurements are made possible with the use of a multi-wire probe capable of geometrically distinguishing flow from multiple directions. Spatial and temporal resolution is related to film/wire size and sampling rate, but cover a range from 10⁻³-1 mm³ and 1 kHz or better [5]. A comparative overview of the different flow measurement techniques is given in **Error! Reference source not found.**

This study to date concentrated on the field techniques, ADCP and ADV. In order to compare the effects of these measurement techniques, the inherent error of an ADCP was first simulated in Matlab. Next, the results of this simulation were verified using experimental data. Recommendations are made for potential corrections to be applied to field or lab data obtained with an ADCP.

SIMULATION

To simulate the effect of sampling a turbulent flow with an ADCP, a synthetic time series of turbulent radial velocity was generated from a prescribed spectral density following a simple power law of $S = f^{-3}$. This simplified relationship represents the decreasing energy contained at decreasing length scales (or increasing oscillating frequencies) in the ocean and provides a benchmark for comparison. A second time series was generated following the same power law, but with a phase shift corresponding to the spatial discrepancy between beam measurement locations. These two time series of radial velocity

were then “sampled” with the simulated ADCP by performing the coordinate transformation

$$w = \frac{v_{r1}}{\sqrt{1 + B^2} \cos \left[\theta - \tan^{-1} \left(\frac{1}{B} \right) \right]} \quad (1)$$

$$u = Bw \quad (2)$$

where the radial and Cartesian components of velocity are as labeled in Figure 1, and θ is the angle formed by the divergent acoustic beams with the horizontal. The simplifying coefficients r and B are given by,

$$r = \frac{v_{r1}}{v_{r2}} \quad (3)$$

$$B = \frac{r + 1}{r - 1} \tan \theta \quad (4)$$

Figure 1 illustrates this coordinate transformation. The radial velocities of two acoustic scatterers occupying the same horizontal plane are each sampled by different divergent acoustic transducers and are assumed to have the same Cartesian velocity components u and w .

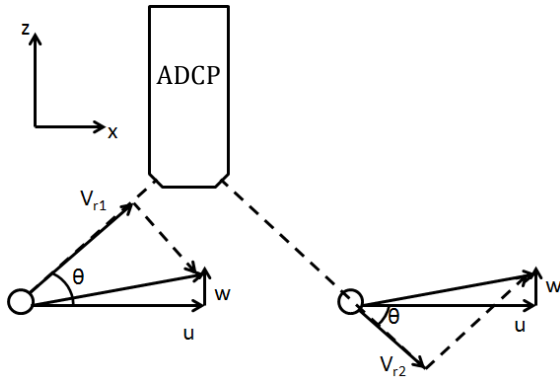

FIGURE 1. ADCP COORDINATE TRANSFORMATION DIAGRAM.

This simplified simulation does not take into account error introduced by acoustic noise or insufficient seeding, but it is illustrative of the error introduced by the geometric assumptions inherent to this measurement technique.

Figure 2 shows the result of these assumptions on the sampled spectral density. Note that the energy contained at higher frequencies is misrepresented lower in the spectrum. This effect is explained in part by aliasing. Aliasing occurs if the sampling rate of the measurement device is below the Nyquist rate; defined to be twice the highest component frequency of the sampled signal. When aliasing

occurs, the energy contained in the upper spectrum will be misrepresented in the lower spectrum in unpredictable ways. The two ways to avoid aliasing are to pre-filter the continuous signal before sampling, or to sample at a faster rate. Once aliasing has been introduced into the sampled signal, it cannot be distinguished from real variability.

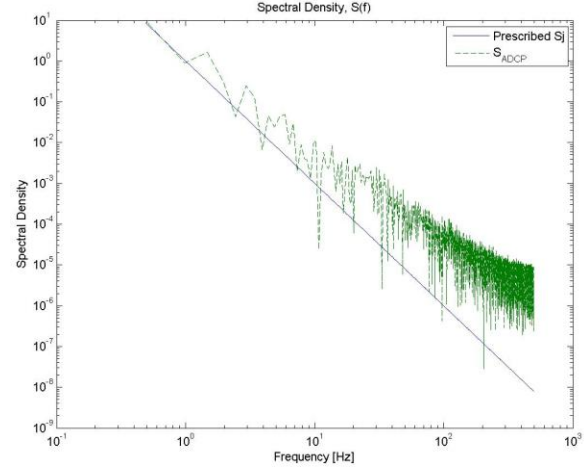

FIGURE 2. SIMULATED ADCP SPECTRAL DENSITY.

FIELD EXPERIMENT

To validate the results of this simulation, field data of the inflow upstream of a MHK device test deployment was analyzed in a similar fashion. This experimental data was measured from a floating platform-mounted ADCP and ADV deployed at the UNH-CORE Tidal Energy Test Site in Great Bay Estuary, NH at General Sullivan Bridge. The test site is located at a constriction through which the Great Bay tidal estuary drains and refills on an approximate 6-hour cycle. The test site has a minimum depth of 8 m at lower low water (LLW) and maximum currents over 2.6 m/s (5 kts), making it an ideal location for testing intermediate scale MHK devices. Additional information on the UNH-CORE Tidal Energy Test Site and details of the deployment that generated the field data presented here are reported in Rowell et al. (2013) [6]. During the 3.5 hour deployment, from slack water through maximum current, there was a 42 minute period during which the current was nearest its maximum. This sub-record of approximately constant velocity flow, shown in Figure 3, is used for comparing the two devices. Note that, while this illustrative plot has been filtered with a 30 sec. running average, the data used in the processing throughout the remainder of this report is unfiltered.

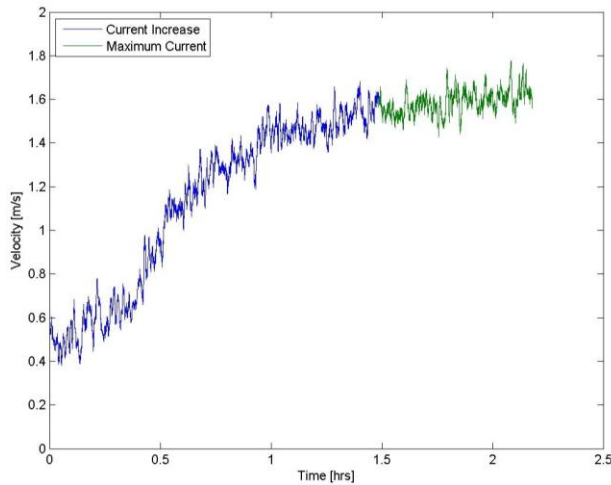

FIGURE 3: TIME SERIES OF INCOMING TIDE AT THE UNH-CORE TIDAL ENERGY TEST SITE, AS MEASURED BY AN ADCP. 42 MINUTE SUBRECORD AT MAXIMUM CURRENT IS SHOWN IN GREEN.

A Nortek Vector ADV was mounted to the bow of the platform at a cross-stream offset from the centerline of 91.4 cm and operated at a frequency of 33.3 Hz. Also mounted on the bow at the centerline adjacent to the ADV was an RDI Sentinel-V ADCP measuring individual acoustic pings (without averaging) at a frequency of 2.0 Hz with a bin size of 10 cm. The ADV was measuring at a depth of 145 cm that corresponds to the seventh ADCP measurement bin, accounting for ADCP blanking distance. A schematic of the experimental setup is shown in Figure 4. Note that the MHK turbine with a nominal diameter of about one meter was mounted 5.7 m downstream of these measurement devices. With a beam divergence of 20°, the aft-facing ADCP beam sampled at a location over 4.7 m (or 9.4 diameters) upstream of the turbine hub. Thus the effects of the MHK turbine on the upstream inflow measurements could be neglected.

In order to verify the accuracy of the mean velocity measurements for each device, the mean velocity profile over the duration of the 42 minute time series is plotted in Figure 5. The mean velocities measured at the same depth with both the ADCP and ADV agree within 0.35%. For reference, a logarithmic velocity profile for open channel flow over rough surfaces was also plotted. The logarithmic velocity profile is given by [7]

$$\bar{u} = 5.75u_\tau \log \frac{30y}{k} \quad (5)$$

where u_τ is the friction velocity, y is the height from the channel bottom, and k is the Nikuradse sand roughness chosen to be 3 in this case. The friction velocity u_τ was estimated using a linear regression analysis to be 0.2 m/s. Note that the Reynolds number based on channel depth is about 16 million.

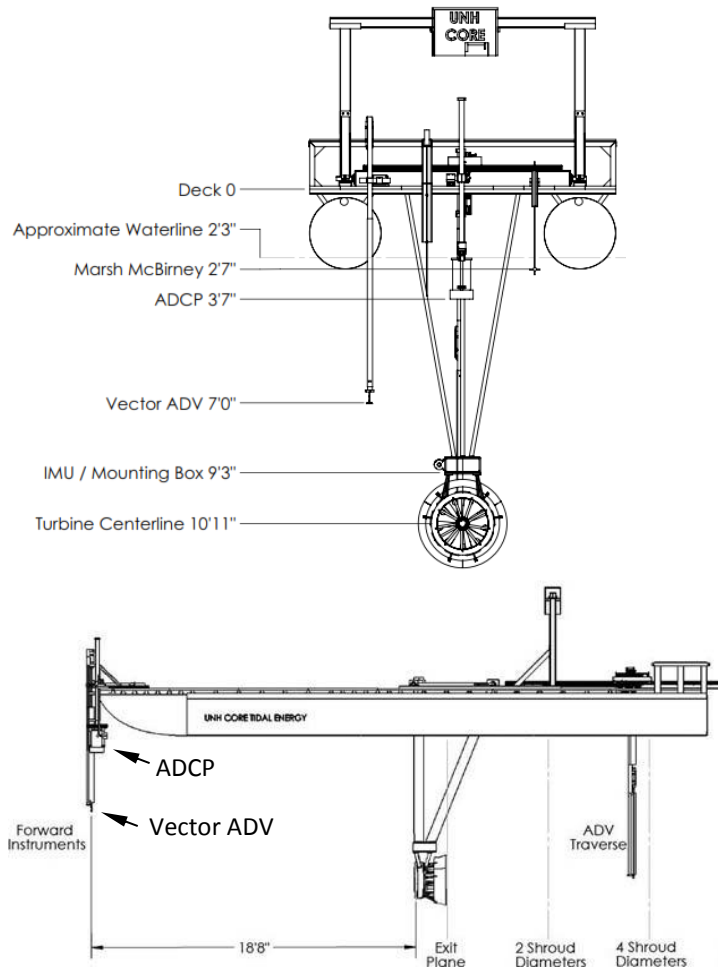

FIGURE 4. SETUP OF INSTRUMENTS ON BOW OF UNH TIDAL ENERGY TEST PLATFORM [6].

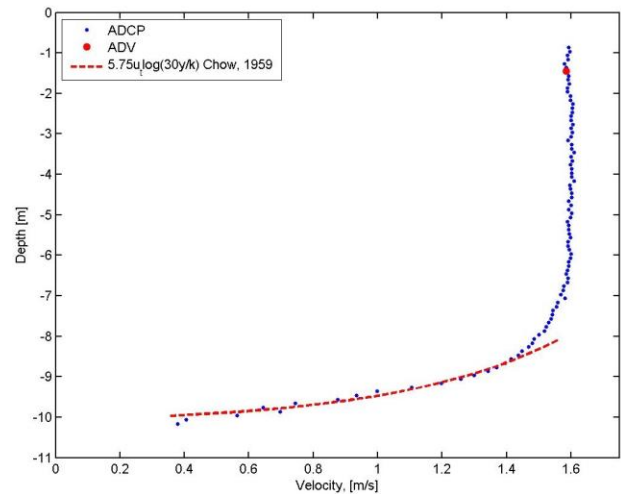

FIGURE 5. MEAN VELOCITY MEASURED WITH ADV (POINT) AND ADCP (PROFILE). LOGARITHMIC PROFILE FOR OPEN CHANNEL FLOW [7] INCLUDED FOR COMPARISON.

Although the mean velocity measurements taken by the two devices agree, and the ADCP measurements agree with the

logarithmic profile for open channel flow in an intermediate region, the apparent velocity fluctuations measured by each device differ greatly. Turbulence intensity is defined as the standard deviation (or square root of the variance) of the velocity fluctuations normalized by the mean velocity.

$$TI = \frac{\left(\frac{1}{N} \sum_{n=1}^N (u_N - \bar{u})^2\right)^{0.5}}{\bar{u}} \quad (6)$$

The turbulence intensities measured by the ADCP and ADV at the same measurement depth over the 42 minute at near maximum velocity are 19.5% and 7.2%, respectively. The higher standard deviation in the ADCP velocity time series is indicative of the errors introduced by the operating principles of the device, in particular the small “bins” and single ping used by the ADCP. Similar results were produced by experiments conducted in Puget Sound with ADCP and ADV turbulence intensities of 11.4% and 8.4%, respectively [8]. This discrepancy is smaller than that shown here in part because of the 5-min running averages applied to the data collected at Puget Sound. This has the effect of smoothing the time series, reducing the variance, and consequently the turbulence intensity. The profile of turbulence intensity as measured by the ADCP is plotted in Figure 6 with the ADV turbulence intensity included for comparison.

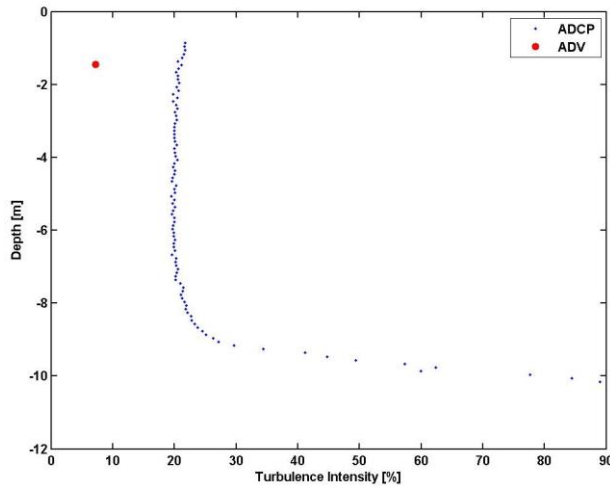

FIGURE 6. TURBULENCE INTENSITY OBTAINED WITH AN ADV (POINT) AND AN ADCP (PROFILE).

Subsequently, Doppler noise was removed from the ADCP measurements to correct towards the ADV measurements using the empirical definition as performed in [8] by the following equations,

$$TI = \frac{\sqrt{\langle u'^2_{ADCP} \rangle - n_e^2}}{\bar{u}} \quad (7)$$

$$n_e = \sqrt{\langle u'^2_{ADCP} \rangle - \langle u'^2_{ADV} \rangle} \quad (8)$$

where n_e is the empirical definition of Doppler noise, and brackets indicate a 5 min. average. The results of this correction can be seen in Figure 7.

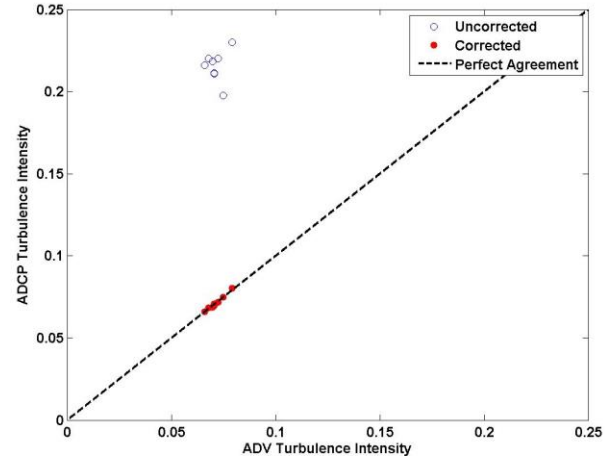

FIGURE 7: ADCP TURBULENCE INTENSITY VS. ADV TURBULENCE INTENSITY, BEFORE AND AFTER CORRECTING FOR DOPPLER NOISE.

As stated by [8], this is only a correction in the statistical sense and not a correction to individual fluctuations. This becomes evident when looking at the spectral density of the ADV and ADCP data in Figure 8, where the same aliasing effect created in the previous simulation is observed. The ADV spectral density follows the expected power law trend and exhibits an increase in energy in the range of 0.1 Hz corresponding to 10 second oscillations. The apparent noise floor of the ADV in this application obscures spectral information at frequencies greater than approximately 3 Hz. The combined effects of aliasing and the noise floor of the ADCP make this level of detail impossible to distinguish.

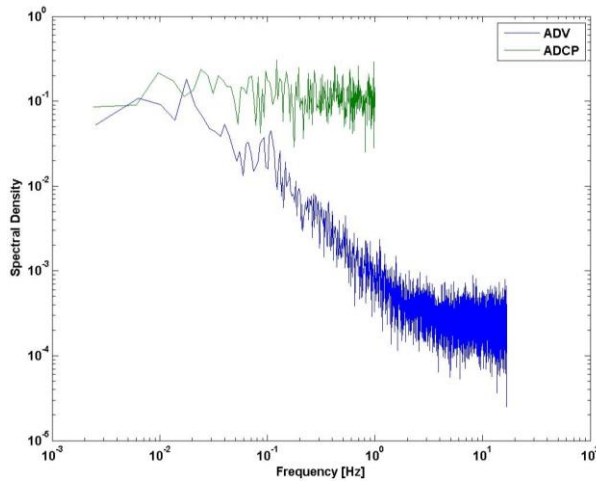

FIGURE 8. SPECTRAL DENSITY OF VELOCITY MEASUREMENTS OBTAINED AT THE SAME MEASUREMENT DEPTH USING AN ADV AND ADCP

The misrepresented velocity fluctuations are occurring at a frequency of critical importance to turbine operation. In Chamorro et al. 2013 [9], it was shown that the wake of an axial flow hydrokinetic turbine is dominated by blade tip vortices. If the ADCP is incapable of resolving these fluctuations, both blade design and array spacing will suffer.

Ideally, an ADV could be used to measure the spectrum at varying depths, creating a full and accurate profile of spectral density. However, the high spatial resolution of the device would require so many measurement locations that this process is impractical. For open channel flow, one measurement location should be used to infer the spectral density over the depth of the channel. The lack of variation in the ADCP spectral density over varying depths indicates that this assumption will hold for measurement locations far enough from the bottom to avoid boundary effects.

SUMMARY AND FUTURE WORK

ADCP's commonly employed for robust field measurements and resource characterization have been shown to be inadequate for resolving the spatial and temporal scales of critical importance to MHK turbine design and deployment. Although ADCP data can be smoothed and averaged and even corrected such that the turbulence intensity agrees with that measured by an ADV, the spectrum and sampling frequency suggests that blade-scale turbulent fluctuations will still be misrepresented. In order to resolve higher frequency oscillations, it is recommended that concurrent ADV measurements be made at a higher sampling rate and over shorter sample periods. These measurements taken in tandem will provide both an accurate long-term mean

velocity profile as well as a well resolved spectral density at a point.

In the future, additional simultaneous ADCP and ADV measurements should be obtained at varying depths in order to verify the assumption that spectral density does not vary significantly with depth in open channel flow.

Ongoing work includes comparison of ADCP and ADV measurements with higher resolution optical flow measurement (high frame rate PIV) in a large cross-section tow tank, for a number of canonical turbulent flows, e.g., flow in the wake of a cylinder and downstream of a grid.

ACKNOWLEDGEMENTS

This research was made possible by funding provided by Massachusetts Clean Energy Center & New England Marine Renewable Energy Center, and NSF CBET-1150797 (program manager: Gregory Rorrer). The authors acknowledge discussions with T. Lippmann, data provided by M. Rowell, and assistance with ongoing tow tank experiments by P. Bachant, I. Nedyalkov, J. Turner, and E. Carlson. The authors thank the National Renewable Energy Laboratory (F. Driscoll, E. Nelson) and Teledyne-RDI for the loan of the Nortek vector ADV for the deployments in 2012 [6].

REFERENCES

- [1] Gilboy, T.P., Dickey, T.D., Sigurdson, D.E., Yu, X., Manov, D., 2000, "An intercomparison of current measurements using a vector measuring current meter, an acoustic Doppler current profiler, and a recently developed acoustic current meter," *Journal of Atmospheric and Oceanic Technology*, 17(1), pp. 561-574
- [2] Voulgars, G., Trowbridge, J.H., 1998, "Evaluation of the acoustic Doppler velocimeter (ADV) for turbulence measurements," *J Atmospheric and Oceanic Technology*, 15(1), pp. 272-289
- [3] Prasad, A.K., 2000, "Particle image velocimetry," *Current Science*, 79(1), pp. 51-60
- [4] Le Duff, A., Plantier, G., Gazengel, B., 2005, "Real-Time Particle Detection and Velocity Measurement by Means of Laser Doppler Velocimetry," *IMTC 2005 - Instrumentation and Measurement*, pp. 2222-2225
- [5] Bruun, H.H., 1996, "Hot-film anemometry in liquid flows," *Meas. Sci. Technol.*, 7(1) pp. 1301-1312
- [6] Rowell, M., Wosnik, M., Barnes, J., King, J.P., 2013, "Experimental Evaluation of a Mixer-Ejector Marine Hydrokinetic Turbine at Two Open-Water Tidal Energy Test Sites in NH and MA," *Mar Technol Soc J*, 47(4) pp. 67-79

- [7] Chow, V. T., 1959, "Open Channel Hydraulics" Mc-Graw Hill
- [8] Thomson, J., Polagye, B., Durgesh, V., Richmond, M.C., 2012, "Measurements of turbulence at two tidal energy sites in Puget Sound, WA," *IEEE J Oceanic Eng*, 37(3), pp. 363-374
- [9] Chamorro L.P., Hill, C., Morton, S., Ellis, C., Arndt, R.E.A., Sotiropoulos, F., 2013, "On the interaction between a turbulent open channel flow and an axial flow turbine," *J Fluid Mech*, 716(1), pp. 658-670